

Pressure-dependent shut-off valve type CDSV

for mounting in simple tapped holes

Pressure p_{max} = 600 bar
Flow Q_{max} = 8 lpm

Further cartridge valves:

- Pressure controlled 2/2-way directional valve type CNE D 7710 NE
- Shut-off valves and throttles type CAV D 7711
- Check valves type CRK, CRB, CRH D 7712
- Throttle and restrictor check valves type CQ, CQR, and CQV D 7713
- 2-way flow control valve type CSJ D 7736
- Pressure reducing valves type CDK D 7745

1. General information

The shut-off valves type CDSV safeguard individual hydraulic consumers from higher pressure by blocking the inlet line. They are typically used to protect pressure gauges or accumulators.

The valve is designed as a cartridge valve. The simple mounting hole can be easily machined by means of standard drill and screw tap.

The shut-off valve is a pressure actuated 2/2-way directional seated valve, enabling free flow from pump side A to consumer side B below the set pressure. A spring loaded control piston is moved upwards in the housing as soon as the set pressure is achieved. The actual valve element is a ball which is then no longer fixed in its position and therefore will follow the flow force (aided by a small spring) thereby blocking the passage with zero leakage.

As soon as the pressure on the primary side A drops below the one apparent at B, the passage will be opened again enabling free flow B to A.

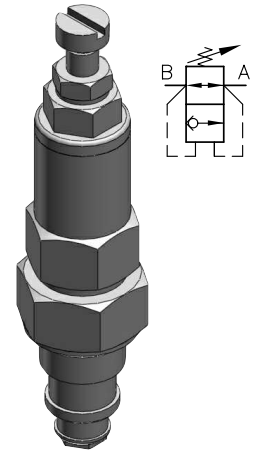

2. Available versions, main data

Order example:

CDSV 1 A - 1/4 - 400

Pressure specification (bar)

Basic type Size	Flow Q_{max} (lpm)	Pressure range (bar)
CDSV 1	8	A 100 ... 600
		B 30 ... 230
		C 10 ... 100
		D 3 ... 30

Version	
No coding	Cartridge valve
- M 10 x 1	M 10 x 1 Including a connection block with: tapped ports (A and B) metric thread
- 1/4	G 1/4 Tapped ports (A and B)
- 3/8	G 3/8 DIN ISO 228/1 (BSPP)

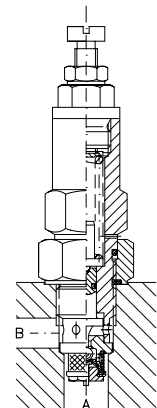

3. Further parameters

Nomenclature	Pressure-dependent shut-off valve
Design	Seated ball valve
Surface	Nitrous hardened
Installed position	Any
Flow direction	Operation direction A → B Return flow B → A
Mass (weight)	Type CDSV 1. = approx. 140 g; Type CDSV 1..-1/4 (- 3/8, - M 10 x 1) = approx. 400 g;
Hydraulic fluid	Fluids acc. to DIN 51524 table 1 to 3; ISO VG 10 to 68 acc. to DIN 51519 Viscosity range: min. approx. 4; max. approx. 1500 mm ² /s Optimal operation range: approx. 10...500 mm ² /s Also suitable are biologically degradable pressure fluids of the type HEPG (Polyalkylenglycol) and HEES (synth. Ester) at operation temperatures up to approx. +70°C. There are also versions available for brake fluid (glycol based) = DOT 4. Coding for such versions is suffix - AT added to the order coding.
Temperature	Ambient: approx. -40...+80°C Fluid: -25...+80°C, pay attention to the viscosity range! Start temperature down to -40°C are allowable (Pay attention to the viscosity range during start!), as long as the operation temperature during subsequent running is at least 20K higher. Biological degradable pressure fluids: Pay attention to manufacturer's information. With regard to the compatibility with sealing materials do not exceed +70°C.

Δp-Q curve

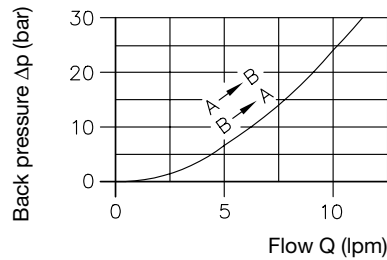

Viscosity of the oil during tests approx. 63 mm²/s

4. Unit dimensions

All dimensions in mm, subject to change without notice !

Basic type CDSV 1..

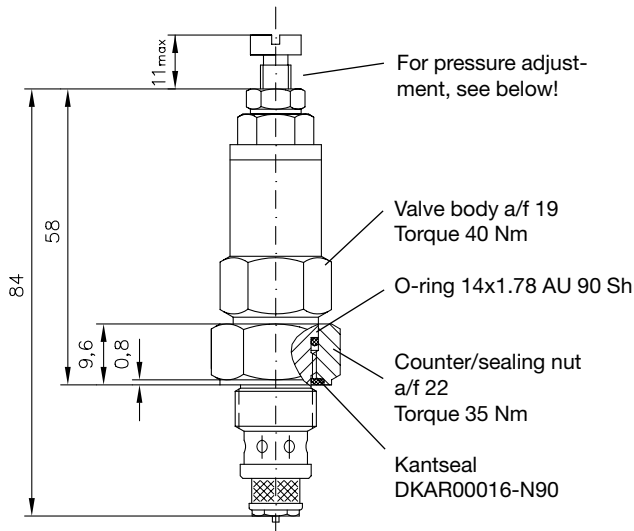

Housing version Type CDSV 1.. - 1/4 - ... Type CDSV 1.. - 3/8 - ... Type CDSV 1.. - M 10 x 1 - ...

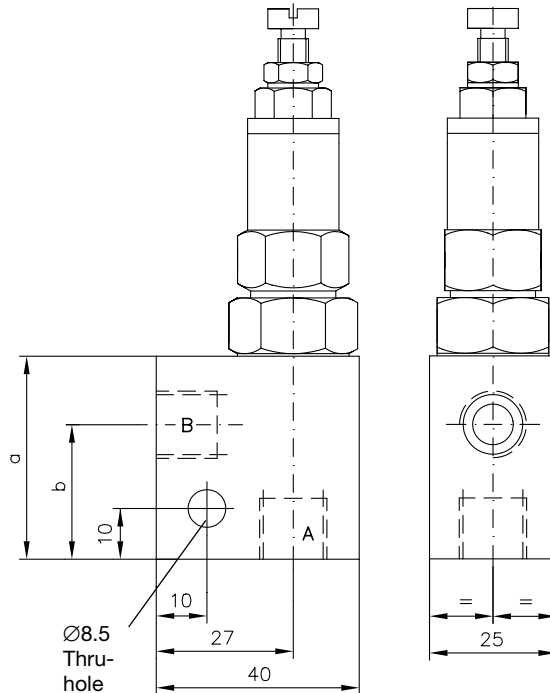

Mounting hole

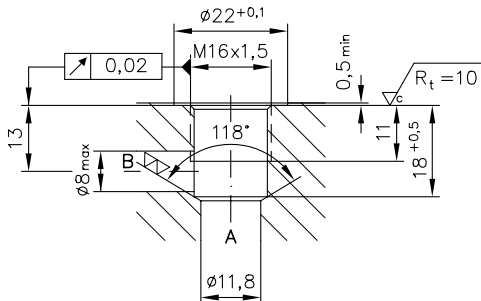

Ports A and B Type

Type		a	b
CDSV 1..-1/4	G 1/4	40	26
CDSV 1..-3/8	G 3/8		
CDSV 1..-M 10 x 1	M 10 x 1	42	28.5

Surface zinc galvanized

Installation:

1. Slacken the counter/sealing nut until the travel stop, prior to screwing the valve body into the manifold.
2. Screw in the valve body (a/f 1) and tighten with the correct torque.
3. Retighten the counter/sealing nut with the correct torque.

Tapped plugs

Mounting holes in the manifold may be blocked if required by tapped plugs, e.g. if uniform manufactured manifolds should be equipped with or without cartridge valves depending on application.

Pressure adjustment

Pressure range	Travel f _{max} (mm)/ Δp (bar) per turn
D	6/6.4
C	5/23
B	4.5/50
A	4.5/135

Passage open

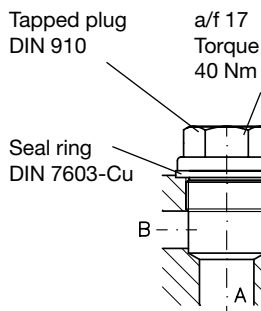

Passage blocked

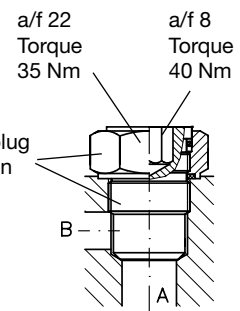

Tapped blockage/plug combination complete
Part No. 7712 003

For mounting hole see above!