

Pressure-controlled shut-off valve type CNE

Product documentation



Screw-in valve

Operating pressure p_{\max} : 500 bar

Flow rate Q_{\max} : 30 lpm



© by HAWE Hydraulik SE.

The forwarding and reproduction of this document, as well as the use and communication of its contents, are forbidden unless expressly permitted.

Any breach or infringement will result in liability for damages.

All rights reserved concerning patent or utility model registrations.

Contents

1	Overview of shut-off valves type CNE.....	4
2	Available versions, main data.....	5
2.1	Basic type (cartridge valve).....	5
2.2	Version with indiv. single connection block.....	6
3	Parameters.....	7
3.1	General.....	7
4	Dimensions.....	9
4.1	Basic type (cartridge valve).....	9
4.2	Mounting hole.....	10
4.3	Version with indiv. connection block.....	10
4.4	Tapped plugs.....	11
5	Installation, operation and maintenance information.....	12
5.1	Designated use.....	12
5.2	Assembly information.....	12
5.2.1	Screw in basic type (cartridge valve).....	12
5.2.2	Adjusting pressure.....	13
5.2.3	Creating the mounting hole.....	13
5.3	Operating instructions.....	14
5.4	Maintenance information.....	14
6	Other information.....	15
6.1	Schematic cross-section and wiring example.....	15

1 Overview of shut-off valves type CNE

Pressure-controlled 2 directional valves are a type of pressure control valve. With two combined pump circuits they switch the low-pressure circuit to idle circulation if the pressure value set is reached and exceeded. The high-pressure circuit continues to pump in the common line.

Via a control line the higher pressure holds open the pressure-controlled 2 directional valve type CNE and with it the idle circulation. In the low-pressure circuit the valve acts simultaneously as a pressure-limiting valve. The valve type CNE can be screwed-in and can be integrated into control blocks. The necessary mounting holes are straightforward to make.

Features and benefits:

- Compact design
- Easily produced mounting hole

Intended applications:

- Accumulator charged systems
- Jigs



Figure 1: Basic version (cartridge valve)

2 Available versions, main data

2.1 Basic type (cartridge valve)

Symbol:



Figure 2: (detailed)

Order coding example:

CNE 2	C	- 50	- 1/2
CNE 22	B	- 350	

Version Table 3 Version with indiv. single connection block

Pressure setting (bar) Pressure setting within the various pressure ranges

Pressure range Table 2 Pressure range

Type and size Table 1 Type and size

Table 1 Type and size

Type and size	Flow Q_{max} (lpm)	Description
CNE 2	30	Shut-off valve
CNE 21		Shut-off valve, additional thread seal
CNE 23		Shut-off valve, additional thread and piston seal
CNE 22		Shut-off valve, additional thread and piston seal

Table 2 Pressure range

Type and size	Pressure range from ... to (bar)						
	L	M	A	B	C	D	E
CNE 2	120 ... 150	95 ... 120	75 ... 95	60 ... 75	45 ... 60	30 ... 45	20 ... 30
CNE 21							
CNE 23							
CNE 22	320 ... 450	150 ... 320

2.2 Version with indiv. single connection block

Order coding example:

CNE 2 C - 50 - 1/2

Indiv. single connection block Table 3 Version with indiv. single connection block

Pressure setting (bar) Pressure setting within the various pressure ranges

Basic version and pressure range Table 1 Basic version, Table 2 Pressure range

Table 3 Version with indiv. single connection block

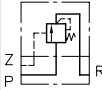
Coding	Description	Symbol
No designation	Cartridge valve	See Chapter 2.1, "Basic type (cartridge valve)"
- 1/2	For pipe connection (G 1/2)	

3 Parameters

3.1 General

General information

Nomination	Pressure controlled shut-off valve		
Design	Spool type valve		
Model	Cartridge valve, valve for pipe connection		
Material	Steel; nitrided valve housing, electrogalvanised sealing nuts and connection block, hardened and ground functional inner parts		
Installation position	Any		
Ports	<ul style="list-style-type: none"> ▪ Port P = Inlet (pump side) ▪ Port R = Outlet (return $p_R \leq 50$ bar) ▪ Port Z = Control port 		
Hydraulic fluid	<p>Hydraulic oil conforming DIN 51 524 part 1 to 3; ISO VG 10 to 68 conforming DIN 51 519 Viscosity limits: min. approx. 4, max. approx. 1500 mm²/s opt. operation approx. 10... 500 mm²/s. Also suitable are biologically degradable pressure fluids types HEPG (Poly-alkylenglycol) and HEES (Synth. Ester) at service temperatures up to approx. +70°C.</p>		
Purity class	ISO 4406 21/18/15...19/17/13	NAS 1638 12 ... 8	SAE T 490 ≥ 6
Temperature	<p>Ambient: approx. -40 ... +80°C, Fluid: -25 ... +80°C, Note the viscosity range! Permissible temperature during start: -40°C (observe start-viscosity!), as long as the service temperature is at least 20K higher for the following operation. Biologically degradable pressure fluids: Observe manufacturer's specifications. By consideration of the compatibility with seal material not over +70°C.</p>		

Pressure and flow

Operating pressure	$p_{max} = 500$ bar		
Static overload nominal volume	Approx. $2 \times p_{max}$ – tightened and sealing nut locked		
Flow	$Q_{max} = 30$ lpm		
Switching hysteresis	Type		
	CNE 2	approx. 6 bar	
	CNE 21	approx. 6 bar	
	CNE 22	approx. 6 bar	
	CNE 23	approx. 12 bar	

Leakage oil

Type CNE 2 and CNE 21: Negligible leakage exists between connections Z→R and Z→P (LP circuit) due to spool and thread clearance. Leakage is only observable when a direct connection to the consumer exists without a directional seated valve in between.

	Leakage flow rate Z→P(R) (cm ³ /min)	
	CNE 2	CNE 21
p _Z = 200 bar	100	55
p _Z = 500 bar	250	160

Weight

Basic version

Type CNE .. = 0.2 kg

With indiv. single
connection block

-1/2 = 0.45 kg

Curves

Viscosity during measurements
approx. 60 mm²/s

Circulation resistance P→R if valve is in working position

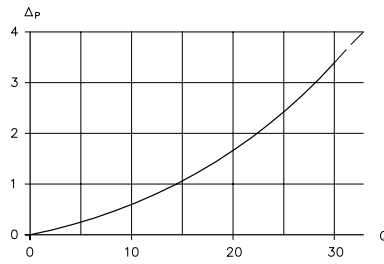

Figure 3: Flow Q (lpm); Flow resistance Δp (bar)

4 Dimensions

All dimensions in mm, subject to change!

4.1 Basic type (cartridge valve)

Type CNE 2

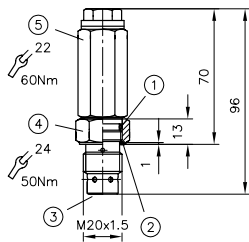

- 1 O-ring 17.17x1.78 AU 90 Sh
- 2 KANTSEAL DKAR 00018-N9011 NBR 90 Sh 18.77x22.13x1.68
- 3 Sealing edge
- 4 Sealing nut
- 5 Valve housing

Type CNE 21, CNE 23

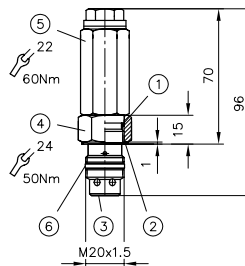

- 1 O-ring 17.17x1.78 AU 90 Sh
- 2 KANTSEAL DKAR 00018-N9011 NBR 90 Sh 18.77x22.13x1.68
- 3 Sealing edge
- 4 Sealing nut
- 5 Valve housing
- 6 Thread seal via seal ring

Type CNE 22

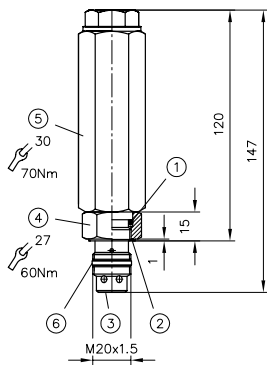

- 1 O-ring 17.17x1.78 AU 90 Sh
- 2 KANTSEAL DKAR 00018-N9011 NBR 90 Sh 18.77x22.13x1.68
- 3 Sealing edge
- 4 Sealing nut
- 5 Valve housing
- 6 Thread seal via seal ring

4.2 Mounting hole

Type CNE 2

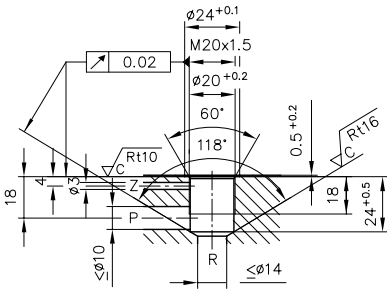

Figure 4: Mounting hole Type CNE 2

Type CNE 21, 22, 23

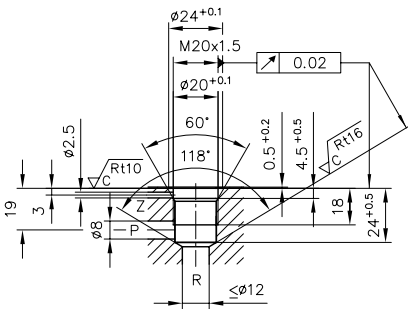

Figure 5: Mounting hole Type CNE 21, CNE 22, CNE 23

The sealing of the inlet to outlet takes place at the contact area between the facial sealing edge of the screwed-in end of the valve body and the stepped shoulder of the core diameter at the location thread.

The stepped shoulder is depicted with the normal 118° drill sharpening angle for steel.

Therefore reaming of the hole and bevels to help the seals slip in are not necessary.

The sealing of the attached valve and its fixing at the manifold body are made by a sealing nut with a special thread seal and an O-ring. Additionally the passage between port A and T is sealed at the screw-in port and the internal piston.



Note

Tapped plugs for the mounting holes, see [Chapter 4.4, "Tapped plugs"](#)

4.3 Version with indiv. connection block

Pipe connection

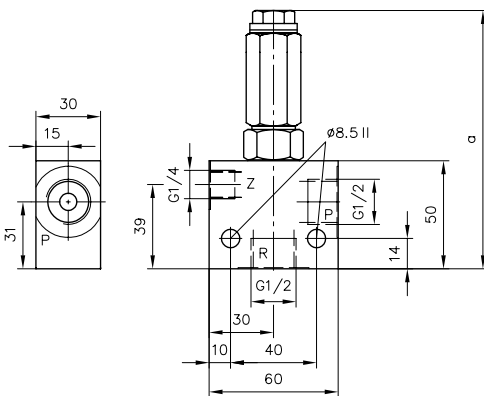

	a
CNE 2	120
CNE 21	
CNE 23	
CNE 22	170

4.4 Tapped plugs

Mounting holes in the manifold may be blocked if required by tapped plugs, e.g. if uniform manufactured manifolds should be equipped with or without cartridge valves depending on application.

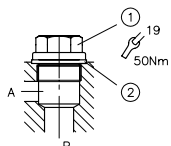

Figure 6: Passage open

- 1 Tapped plug M20x1.5 DIN 910
- 2 Seal ring A20x24x1.5 DIN 7603-Cu

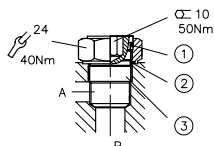

Figure 7: Passage blocked

- 1 O-ring 17.17X1.78 AU 90 Sh
- 2 KANTSEAL DKAR 00018-N9011 NBR 90 Sh 18.77x22.13x1.68
- 3 Tapped blockage / Plug combination

Type	Order no.
CNE 2	Z 7715 019
CNE 21, CNE 22, CNE 23	Z 7745 050

5 Installation, operation and maintenance information

5.1 Designated use

This fluid-power product has been designed, manufactured and tested acc. to standards and regulations generally applicable in the European Union and left the plant in a safe and fault-free condition.

To maintain this condition and ensure safe operation, operators must observe the information and warnings in this documentation.

This fluid-power product must be installed and integrated in a hydraulic system by a qualified staff who is familiar with and observes the general engineering principles and relevant applicable regulations and standards.

In addition, application-specific features of the system or installation location must be taken into account if relevant.

This product may only be used within oil-hydraulic systems.

The product must be operated within the specified data. This documentation contains the technical parameters for various product versions.



Note

Non-compliance will void any warranty claims made against HAWE Hydraulik.

5.2 Assembly information

The hydraulic accumulator must be integrated in the system via state of the art connection components (screw fittings, hoses, pipes, etc.). The hydraulic system must be shut down as a precautionary measure prior to dismounting; this applies in particular to systems with hydraulic accumulators.

5.2.1 Screw in basic type (cartridge valve)

Screw in and locking

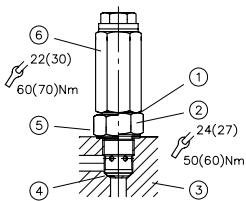

Figure 8: Pressure controlled 2-way directional valve type CNE

- 1 Travel stop
- 2 Counter / Sealing
- 3 Manifold
- 4 Sealing edge
- 5 Counter
- 6 Valve body

1. Before screwing in the valve body loosen the counter/sealing nut until the travel stop.
2. Screw in the valve body and tighten with the specified torque. The metallic sealing of the inlet to the outlet is formed between the facial sealing edge of the valve body and the shoulder of the stepped hole in the manifold.
3. Tighten counter/sealing nut with specified torque.

5.2.2 Adjusting pressure



Caution

Risk of injury on overloading components due to incorrect pressure settings!

- Always monitor the pressure gauge when setting or changing the pressure.

The pressure setting can be changed by adding washers.

Pressure range	Pressure alteration approx. (bar) per mm		Washer order no.	Thickness
	CNE 2, CNE 21, CNE 23	CNE 22		
A	4.2	--	7748 013 a	0.5 mm
B	2.5	32	7748 013 b	1.0 mm
C	1.7	11	7748 013 c	1.2 mm
D	1.1	--	7748 013 d	2.0 mm
E	0.9	--		
L	10.5	--		
M	6.3	--		

For pressure range A to M see also [Chapter 2, "Available versions, main data"](#)

5.2.3 Creating the mounting hole

See description in [Chapter 4.2, "Mounting hole"](#)

5.3 Operating instructions

Product, pressure and/or flow settings

All statements in this documentation must be observed for all product, pressure and/or flow settings on or in the hydraulic system.



Caution

Risk of injury on overloading components due to incorrect pressure settings!

- Always monitor the pressure gauge when setting or changing the pressure.

Filtering and purity of the hydraulic fluid

Soiling in the fine range, e.g. abraded material and dust, or in the macro range, e.g. chips, rubber particles from hoses and seals, can cause significant malfunctions in a hydraulic system. It is also to be noted that new hydraulic fluid "from the drum" does not necessarily meet the highest purity requirements.

For trouble-free operation pay attention to the purity of the hydraulic fluid (see also purity class in [Chapter 3, "Parameters"](#)).

5.4 Maintenance information

This product is largely maintenance-free.

Check that the product is securely fastened in the mounting hole at regular intervals, but at least once per year.

Conduct a visual inspection to check the hydraulic connections for damage at regular intervals, but at least once per year. If external leaks are found, shut down and remedy.

Check the device surfaces for dust deposits at regular intervals (but at least annually) and clean the device if required.

6 Other information

6.1 Schematic cross-section and wiring example

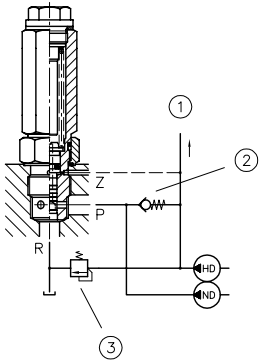

- 1 To the directional valve and the consumer
- 2 Check valve e.g. acc. to D 7712
- 3 Pressure limiting valve for HP-circuit, e.g. acc. type CMV to D 7710 MV

Additional versions and connection blocks

Additional versions

- Throttle valve and shut-off valve CAV: D 7711
- Check valve type CRK, CRB and CRH: D 7712
- Flow control valve type CSJ: D 7736
- Pressure-dependent shut-off valve type CDSV: D 7876
- Pressure valve type CMV, CMVZ, CSV and CSVZ: D 7710 MV
- Pressure-reducing valve type CDK: D 7745
- Pressure-reducing valve type CLK: D 7745 L
- Two-stage valve type NE: D 7161

Connection blocks

- Connection blocks type A for hydraulic power packs:
D 6905 A/1