

Shut-off valves type AVT and AVM

Operating pressure p_{max} = 630 bar
 Flow Q_{max} = 50 lpm

1. General

Conical seated shut-off valves for pipes to pressure chambers in general, to pressure gauges, pressure switch units, control lines, drain lines, connecting lines etc. They allow the drainage (decompression) of pressurized volumes and also switching (pressure build-up) e.g. in the test rig etc. The functional parts are incorporated in the T-housing of standard pipe connections and allow direct pipe connection by way of a cutting ring and union nut. Valve seats and valve cones are hardened and ground, is electrogalvanized. This results in precise blocking of the opening when the valve is closed without the risk of damaging the cone (pressing in when closed too forcibly) and good protection against corrosion of the outside surfaces.

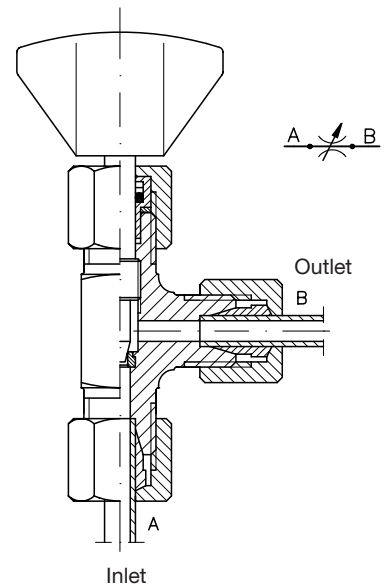

2. Types available, main data

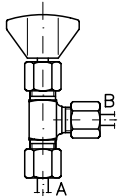
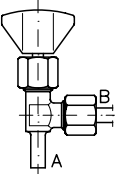
Type	Coding	Connecting pipe \varnothing_A (mm)	Operating pressure p_{max} (bar)		Mass (weight) approx. g
			Outlet B	Inlet A ²⁾	
 <p>with pipe connection on both sides</p>	AVT 6	6	630	630	140
	AVT 8	8	630	630	175
	AVT 10	10	630	630	230
	AVT 12	12	630	630	315
 <p>with pipe socket on one side ¹⁾</p>	AVM 8	8	500	630	110
	AVM 8 L	8	315	315	100

¹⁾ Preferably as pressure gauge shutoff valve. The pipe socket allows the combination with straight screw parts or angle pieces to adjustable connecting elements. Also see D 7077, Sk 6900 H or Sk 7200 M.

²⁾ See sect. 3 "Operating pressure"

3. Characteristic data

Designation and type	Shut-of valve with threaded handle operation
Use	For opening or closing (blocking) lines
Installation pos. and mounting	Any, freely suspended in pipeline
Material and surface protection	Steel. Seat and ball hardened and ground, housing surface galvanized and yellow chromated
Flow direction	Preferably A → B, so that A is the inflow side or the pressure side to be blocked and so that the blocked element (pressure gauge, pressure switch unit) or the continuing pressure line or return line is at B.
Blocking	Effective in both directions
Operating pressure	p_{max} (Sect. 2); correspond to rated pressure with 4-fold safety against bursting Pressure at B: Permissible system pressure when valve is open Pressure at A: Permissible overload capacity at inlet A when the valve is closed
Hydraulic fluid	Fluids acc. to DIN 51524 table 1 to 3; ISO VG 10 to 68 acc. to DIN 51519 Viscosity range: min. approx. 4; max. approx. 1500 mm ² /s Optimal operation range: approx. 10...500 mm ² /s Also suitable are biologically degradable pressure fluids of the type HEPG (Polyalkylenglycol) and HEES (synth. Ester) at operation temperatures up to approx. +70°C.
Temperature	Ambient: approx. -40...+80°C Fluid: -25...+80°C, pay attention to the viscosity range! Start temperature down to -40°C are allowable (Pay attention to the viscosity range during start!), as long as the operation temperature during subsequent running is at least 20K higher. Biological degradable pressure fluids: Pay attention to manufacturer's information. With regard to the compatibility with sealing materials do not exceed +70°C.

Δp -Q-Characteristics

Valid for fully-opened valve

Oil viscosity during measurement approx. 60 mm²/s

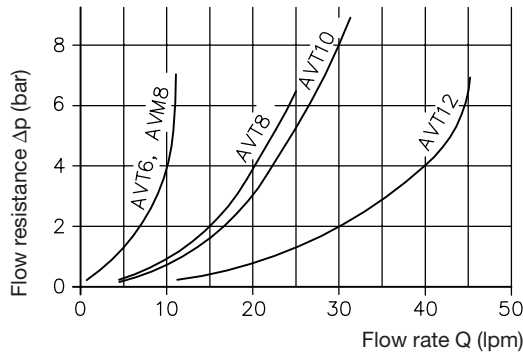

4. Dimensions of units

Type AVT ...

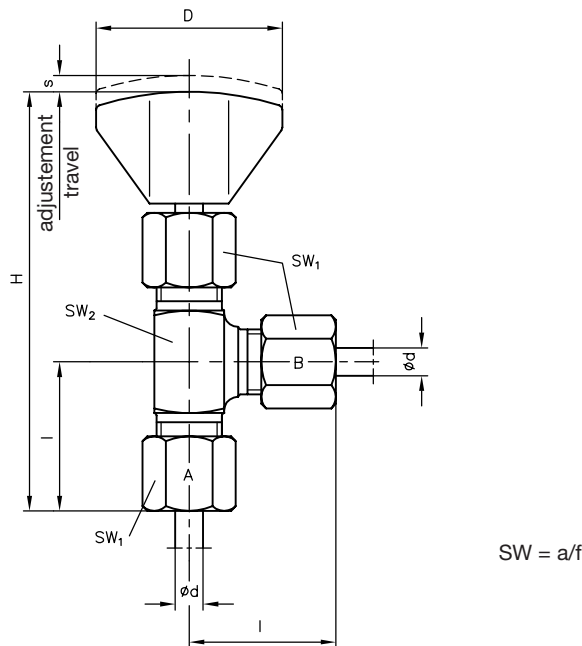

Type AVM 8

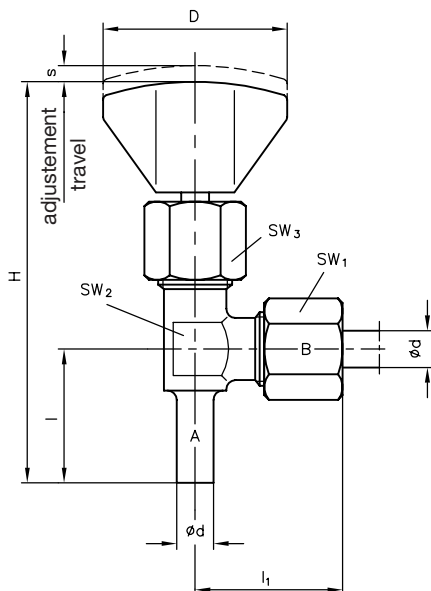

Type	H	D	Ød	l	s	SW1	SW2
AVT 6	91	40	6	31	3	17	14
AVT 8	94	40	8	32	3.5	19	17
AVT 10	94	40	10	34	4.5	22	19
AVT 12	114	50	12	38	5	24	22

Type	H	D	Ød	l	l1	s	SW1	SW2	SW3
AVM 8	91	40	8	29	32	3.5	19	14	19
AVM 8 L	92	40	8	30.5	30	3.5	17	17	19

All dimensions are in mm, subject to change without notice!