

# Precision restrictor type FG and FGS

for screw mounting in the control oil inlets or outlets of hydraulically actuated hydraulic units

Operating pressure  $p_{max} = 300$  (400) bar

## 1. General

The precision throttle serves to delay the switching rate of pressure oil actuated valves:

- Response time setting of directional control valves
- Pulsations prevention
- Vibration dampening

The attenuation effect is achieved by means of thread with an adjustable screw length.

## 2. Available versions, main data

Coding examples:

- FG 1** Throttle screw for screw-in into mounting hole (not available as type FGS)  
**FG 2 - S** Version with thread type throttle and swivel housing  
**FGS H6 K** Version with thread type throttle (locked against complete removal) and swivel housing

Sealing of the mounting hole  
 without = Standard, via sealing edge ring DKA 1/4  
**K** = Seal KDS 14 A3C (only with FGS)

**Table 1:** Basic type and function

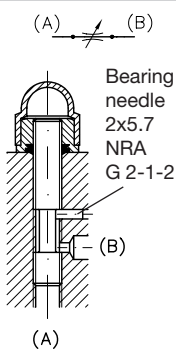
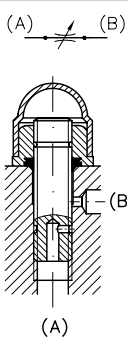
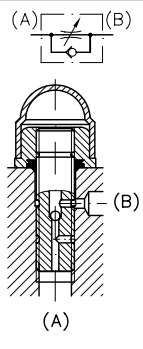
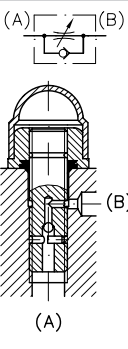
Version	With lock against complete removal	Standard (suited for screw-in into mounting hole)		
Codings, symbol and schematic cross-sectional view	<b>FGS</b> <sup>1)</sup>	<b>FG</b>	<b>FG 1</b>	<b>FG 2</b>
				
Function				
Throttling direction		A → B and B → A	B → A	A → B
Free flow direction		None	A → B	B → A

<sup>1)</sup> Only available as version with swivel housing (see table 2)

**Table 2:** Version with housing

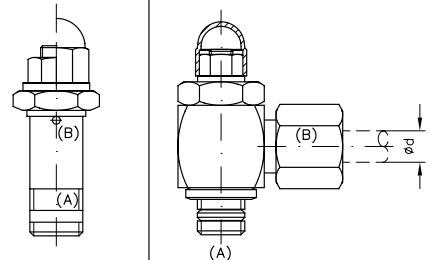
Banjo bolt	Swivel housing	∅d	List of ERMETO components not scope of delivery		
FG FG 1 FG 2			Housing	Tapered an cutting ring	Coupling nut
<b>- S</b>		6	XWH 6-SR-A3C	DPR 6-LS	M 6-S-A3C
			Xswve 6-SR		
		8	XWH 8-SM/SR-A3C	DPR 8-LS	M 8-S-A3C
			Xswve 8-SR		

### 3. Additional data

Design	Thread type throttle
Installed position	Any
Flow	In throttled direction: Depending on the setting, refer to the $\Delta p$ -Q-a curves. The flow rate values are dependent on the viscosity.
Pressure max.	Type FG, FG 1 and FG 2= 300 bar Type FGS = 400 bar
Pressure fluid	Hydraulic oil conforming DIN 51524 part 1 to 3; ISO VG 10 to 68 acc. to DIN 51519 Viscosity limits: min. approx. 4; max. approx. 1500 mm <sup>2</sup> /sec opt. operation: approx. 10 ... 500 mm <sup>2</sup> /sec Also suitable for biological degradable pressure fluids types HEPG (Polyalkylenglycol) and HEES (Synth. Ester) at service temperatures up to approx. +70°C
Temperature	Ambient: approx. -40 ... +80 C Fluid: -25 ... +80°C, note the viscosity range Permissible temperature during start: -40°C (observe start-viscosity!), as long as the service temperature is at least 20 K (Kelvin) higher for the following operation. Biological degradable pressure fluids: Observe manufacturer's specifications. Considering the compatibility with seal material not over +70°C.
Mass (weighth) approx.	Thread type throttle = approx. 15 g Version with banjo bolt = approx. 40 g Version with swivel housing = approx. 110 g

$\Delta p$ -Q curves

Throttled flow direction  
( $\Delta p$ -Q-a)

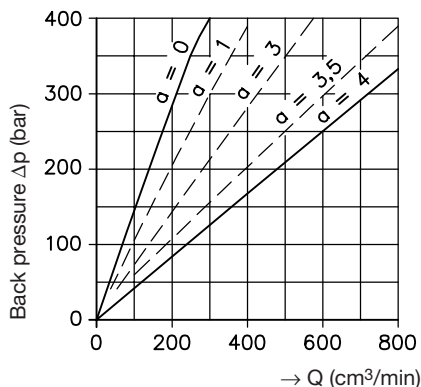

Flow direction

A → B (FG 1...)  
B → A (FG 2...)

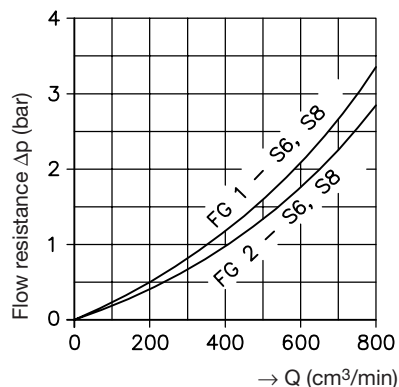

Oil viscosity during measurement 50 mm<sup>2</sup>/s

Viscosity influence: The flow will be reduced in a ratio of approx.  $\frac{50}{p_x}$ , with setting unchanged ( $p_x$  = viscosity).

It is therefore recommended to use a setting for a above 1, when viscosities below 400 to 500 mm<sup>2</sup>/s are anticipated in the later use (applications outside etc.). See also description regarding  $a_{max}$  in sect. 5.

## 4. Dimensions

All dimensions in mm, subject to change without notice!

### 4.1 Throttle screw for screw-in into mounting hole

Type FG, FG 1 and FG 2

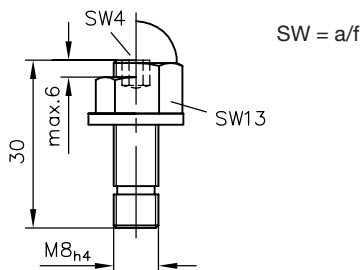

#### Location hole

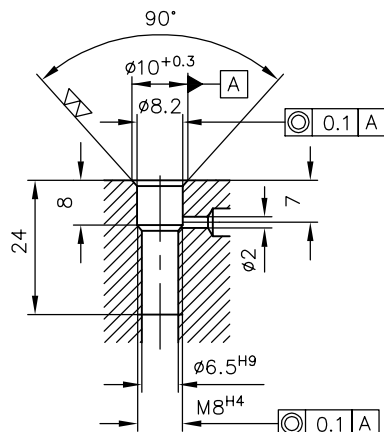

### 4.2 Housing design (swivel housing)

Type FGS H 6(8)  
 FG - S 6(8)  
 FG 1 - S 6(8)  
 FG 2 - S 6(8)

SW = a/f

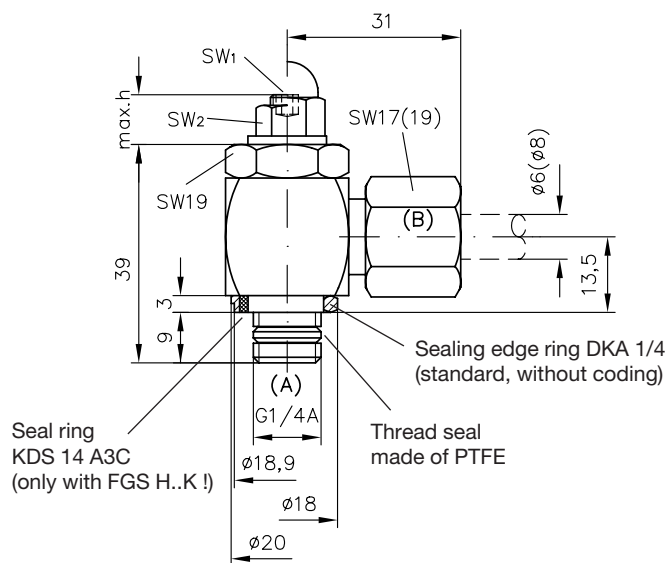

#### Location hole

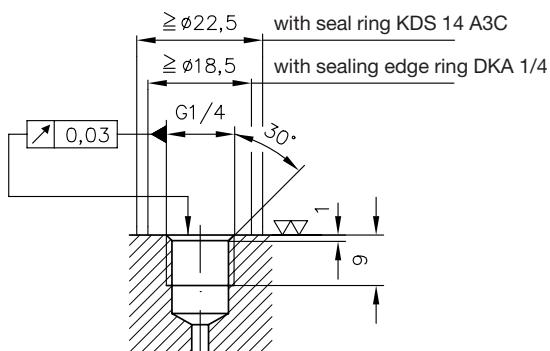

## 5. Instructions for operation

Max. setting range 6 mm

Effective restriction  
from 0 to 4 mm

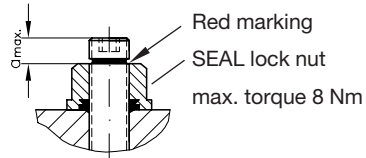

### Setting range a

The greatest throttling action is achieved at  $a = 0$  (the throttle screw and lock nut are flush with one another).

The throttling action is terminated when the red ring mark appears (= end of the permissible setting range). Do not unscrew the throttle screw any farther, since the number of supporting threads will decrease.

Type FGS: Locked via bearing needle 2x5.7 NRA G 2-1-2

Type FG, FG 1(2): The design of the screw does not allow the provision of a mechanical safeguard which would prevent the screw from being unscrewed farther or removed. Hence, special reference must be made in the operation manual or instructions for use to the red mark as the end of the permissible setting range.

If necessary (e.g. for accident prevention), appropriate securing element (a) are to be attached to the manifold into which the FG-screw is inserted, so as to prevent the screw from turning outwards any further.

This also applies to housing designs ...-S, ...-S 6(8).

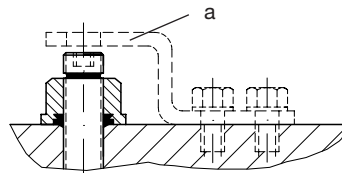

### Lock nut

Prior to setting the throttle screw, loosen the SEAL lock nut completely to remove the tension from the elastomer sealing ring provided in the thread.