

# Proportional pressure reducing valve type KFB 01 (hydraulic joystick)

Control pressure  $p_{\text{contr}}$  = 1 ... 30 bar  
Flow  $Q_{\text{max}}$  = 2 lpm

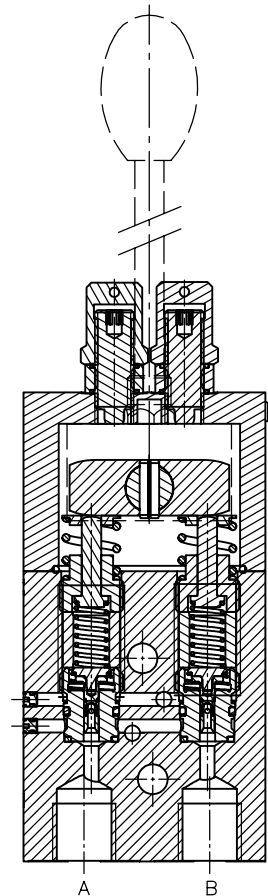

Symbol

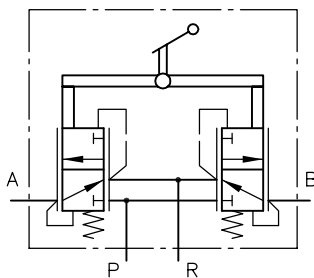

Simplified symbol

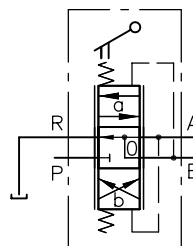

## 1. General information

The proportional pressure reducing valves type KFB is used for a stepless remote control of hydraulic actuators, which respond proportional to variations of the control pressure (range 1 to 30 bar). They are ideally suited for the remote control of directional spool valves type PSL and PSV acc. to D 7700 ++.

Two directly actuated pressure reducing valves, one for each switching direction, are combined in one housing. They supply a control pressure at one of the two outlet ports (to the hydraulic actuators), which is dependent of the movement direction and proportional to the elevation of the hand lever but independent of the inlet pressure. While one of the outlet ports is pressurized the other port is depressurized to the tank.

The proportional pressure reducing valve consists of a control section with the functional elements from the proportional pressure reducing valve type PM 1 and the actuating section (manual operation) which is mounted on top. These valves are available either individually or as valve bank consisting of several valves connected in parallel.

## 2. Available versions, main data

### 2.1 Single valve

Order examples:

**FB 01 - 19 / F 1**

Additional features for actuations

Coding	Description
no coding	with hand lever
<b>1</b>	without hand lever
<b>005</b>	with hand lever 5° cranked (angled 5°)
<b>015</b>	with hand lever 15° cranked (angled 15°)
<b>025</b>	with hand lever 25° cranked (angled 25°)
<b>030</b>	with hand lever 30° cranked (angled 30°)

Manual actuation

Coding	Description
<b>F</b>	Manual actuation with spring return
<b>FC</b>	Friction detent

Pressure range of the prop. pressure reducing valve

Coding	$\Delta p_A = p_A - p_R$ (bar) Setting tolerance 0 + 1.5 bar
<b>30</b>	30
<b>19</b>	19
<b>14</b>	14
<b>11</b>	11.5
<b>9</b>	9
<b>7</b>	7.5
<b>5,5</b>	5.5
<b>4</b>	4.5

Basic type coding single valve

<b>FB 01</b>	Ports G 1/4 (BSPP) (ISO 228/1)
<b>FB 01 UNF</b>	Ports 7/16-20 UNF-2B (SAE-4)

Basic version

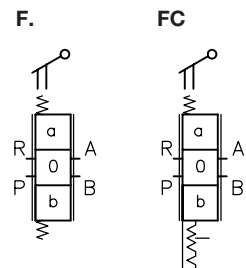

Simplified symbol

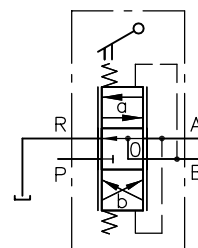

## 2.2 Valve bank

Order examples:

**KFB 01 - A/ 19 / F - M/ 19 / F - E/ 19 / F**

Manual actuation, see sect. 2.1

Valve section

Coding	Description
<b>A/...</b>	First section: With ports P, R, A and B
<b>M/...</b>	Centre sections: Max. 8 sections in total (ports A and B)
<b>E/...</b>	End section: Concludes the valve bank (ports A and B)
<b>E2/...</b>	End section: Concludes the valve bank (ports P, R, A and B)

Pressure range of the prop. pressure reducing valve, see sect. 2.1

Basic type coding individual valve

<b>KFB 01</b>	Ports G 1/4 (BSPP) (ISO 228/1)
<b>KFB 01 UNF</b>	Ports 7/16-20 UNF-2B (SAE-4)

Symbol acc. to the order example

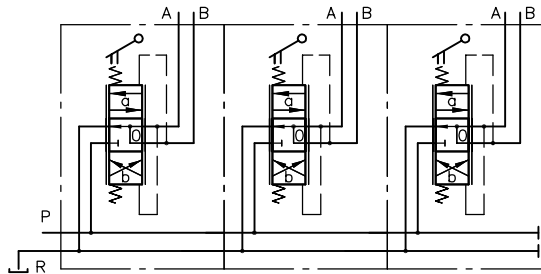

### 3. Technical data

#### 3.1 General parameter

Nomenclature	Proportional pressure reducing valve
Type coding	Individual valve FB 01 - ... Valve bank KFB 01 - ... For complete type coding, see sect. 2
Design	Individual valve or valve bank with max. 10 valve sections
Surface treatment	All parts are corrosion inhibiting gas nitrided
Mounting	M 6 tapped holes, 6 deep (see dimensional drawing)
Pipe connection	P, R, A, B = G 1/4 ISO 228/1 (BSPP) or 7/16-20 UNF-2B (SAE-4)
Dimensions	see sect. 4.1
Mass (weight)	approx. 1.0 kg, per valve section
Installation position	Any
Temperature	Ambient: approx. -40 ... +80°C Fluid: -25 ... +80°C, Note the viscosity range! Permissible temperature during start: -40°C (observe start-viscosity!), as long as the service temperature is at least 20K higher for the following operation. Biologically degradable pressure fluids: Observe manufacturer's specifications. By consideration of the compatibility with seal material not over +70°C.
Flow	Max. approx. 2 lpm
Pressure	$P_{max P} = 120$ bar
Pressure fluid	Hydraulic oil conforming DIN 51524 part 1 to 3: ISO VG 10 to 68 conforming DIN 51519. Viscosity limits: min. approx. 4, max. approx. 1500 mm <sup>2</sup> /sec; opt. operation approx. 10 ... 500 mm <sup>2</sup> /sec. Also suitable are biologically degradable pressure fluids types HEPG (Polyalkylenglycol) and HEES (Synth. Ester) at service temperatures up to approx. +70°C. The viscosity influence on the pressure reduction can be neglected, but observe notes on „Response time“ below.
Response times	There are two different response times:  <b>Response ON:</b> Period from actuating the prop. pressure reducing valve until the consumer connected to the directional spool valve starts moving.  <b>Response OFF:</b> Period from returning the actuation of the proportional pressure valve to idle position until the consumer connected to the directional spool valve has stopped moving.  These response times are strongly influenced by the length and diameter of the hydraulic piping (control lines) between the prop. pressure reducing valve and the control valve as well as the viscosity of the hydraulic fluid.  Example: A response time of approx. 0.5 to 0.7 sec must be expected for a manual-hydraulic remote control system with a pipe length 5 m (one-way length), internal diameter 4 mm and fluid viscosity 30 to 50 mm <sup>2</sup> /sec. Increasing the length or the viscosity by the factor 2 will cause doubled response time; when the diameter is increased from 4 mm to 5 mm the response time would be decreased to approx. 0.5 to 0.7 sec.

Curve

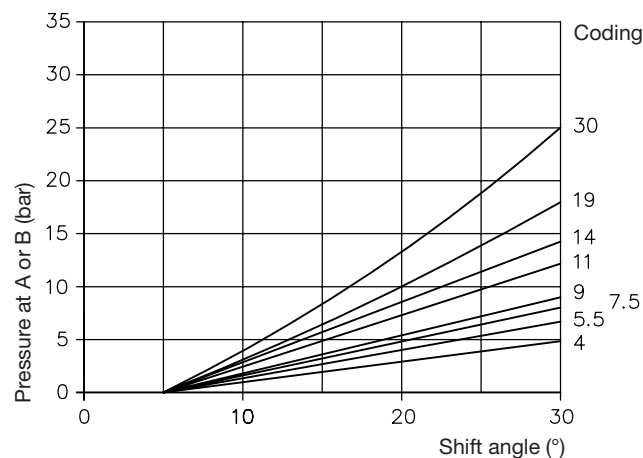

## 4. Unit dimensions All dimension in mm and subject to change without notice!

### 4.1 Valve section

#### Individual valve type FB 01

Ports  
 P, R, A, B = G 1/4 (ISO 228/1) (BSPP)  
 = 7/16-20 UNF-2B (SAE-4)

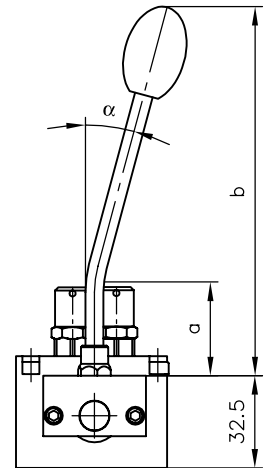
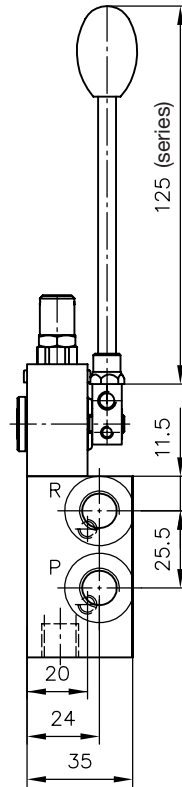
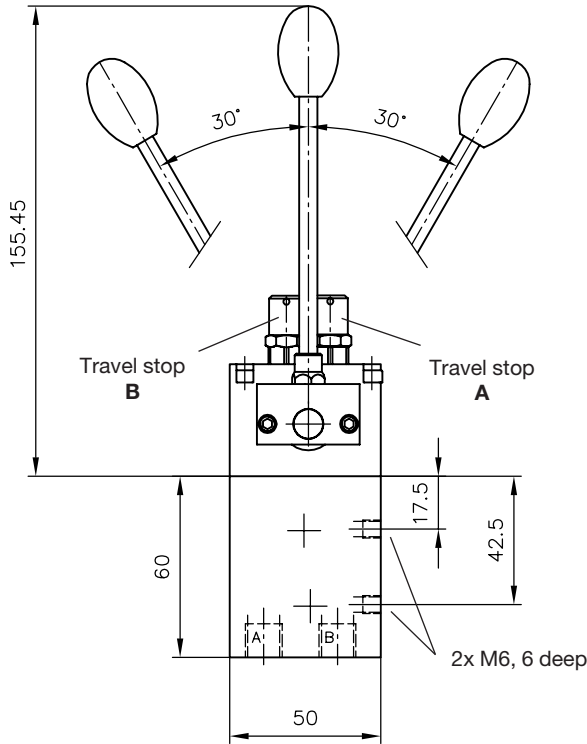
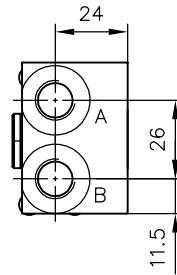

Coding	(approx.) a	(approx.) b	$\alpha$
<b>005</b>	31	124	5°
<b>015</b>	31	122	15°
<b>025</b>	31	117	25°
<b>030</b>	49	116	30°

#### Valve bank type KFB 01

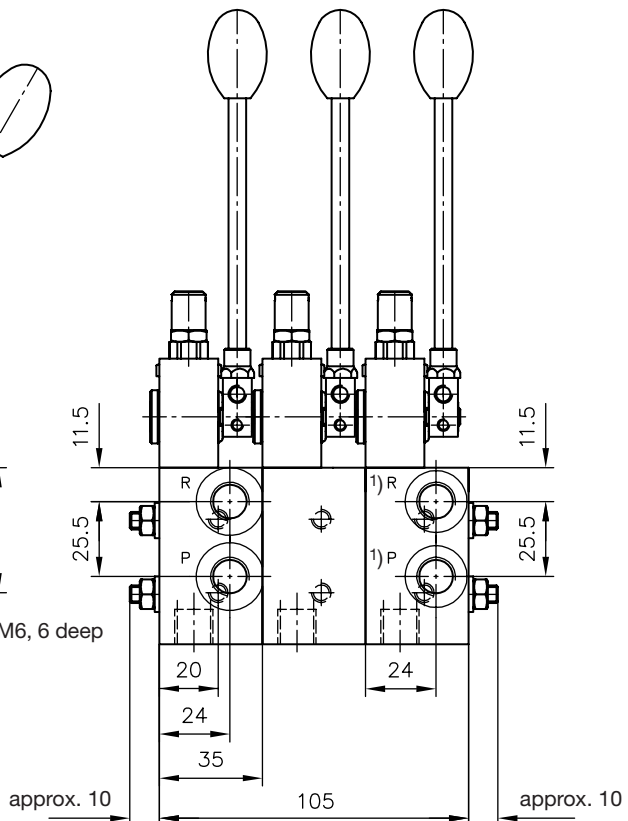
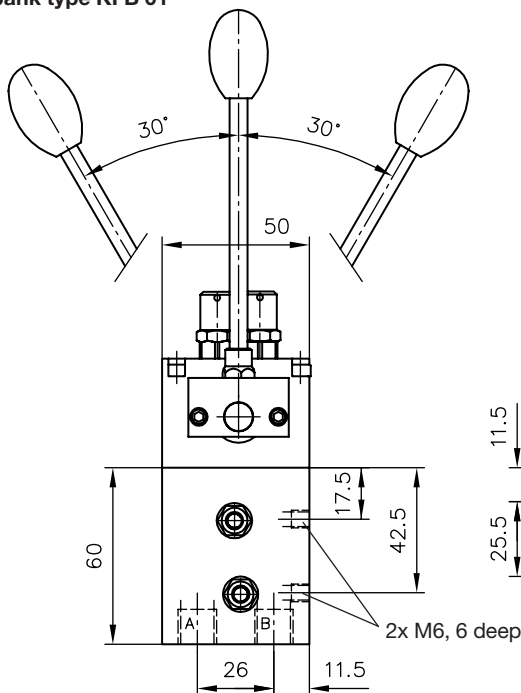

Ports  
 P, R, A, B = G 1/4 (ISO 228/1) (BSPP)  
 = 7/16-20 UNF-2B (SAE-4)

1) P and R only at end section E2/...

## 5. Example circuit

Manual remote control of prop. directional spool valves type PSL acc. to D 7700 ++

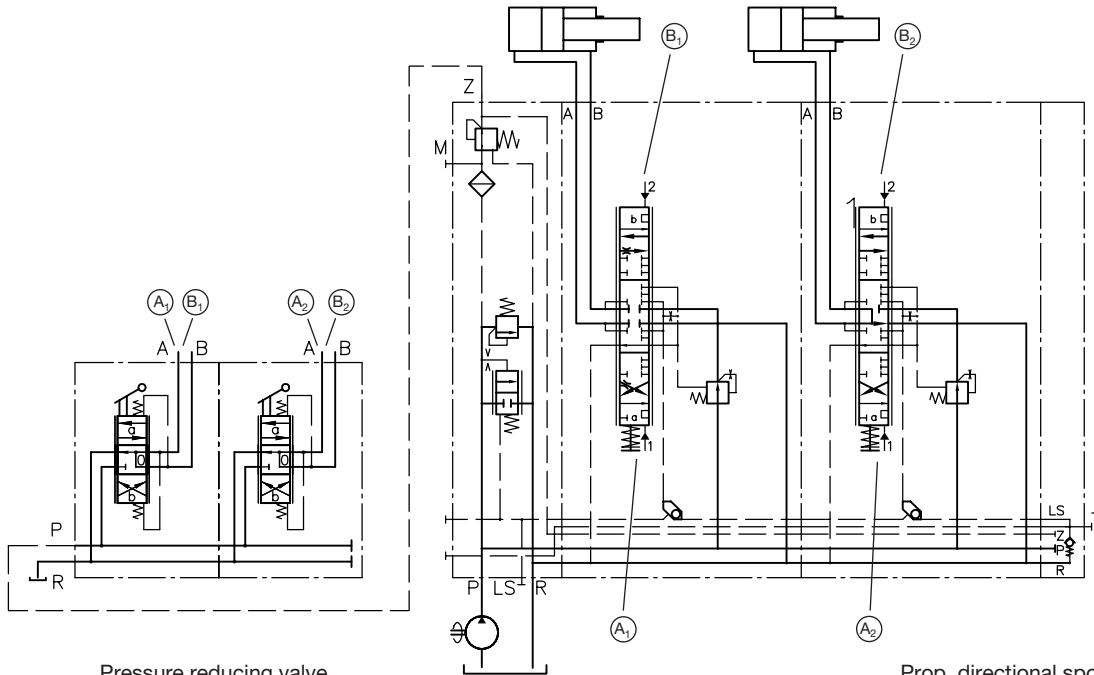

Pressure reducing valve  
KFB 01 - A/19/F - E/19/F

Prop. directional spool valve bank  
acc. to D 7700-3  
PSL 41/350 - 3 - J 25/16/H  
- H 63/40/H  
- E 4